

# Investigation of the Use of Various Silica Source on NaX Zeolite Properties

Atieh Eskandari<sup>1</sup>, Mansoor Anbia<sup>2\*</sup>, Mansour Jahangiri<sup>1</sup>  
and Fariba Mohammadi Nejati<sup>1</sup>

1. Faculty of Chemical, Petroleum and Gas Engineering, Semnan University, Semnan, I.R. Iran.  
2. Research Laboratory of Nanoporous Materials, Faculty of Chemistry, Iran University of Science and Technology, Tehran 16846-13114, Iran.

(Received 7 May 2015, Accepted 11 December 2015)

## Abstract

Silicon and aluminum sources are most important reactants in the synthesis of zeolite. The use of the silicon source has an important effect on the crystallization of zeolites. Also, it can change the properties of the end product. This work reports the influence of three common commercial silica sources such as colloidal silica (Ludox AM-30), fumed silica and water glass on the crystallinity of NaX zeolite by hydrothermal method, also the adsorption of carbon dioxide on these samples have also been studied. The synthesized samples from different sources are characterized by X-ray diffraction (XRD), scanning electron microscope (SEM), Fourier transform infrared (FT-IR) and nitrogen adsorption-desorption analysis. The sample obtained by fumed silica, colloidal silica and water glass is NaX phase. The percentage of crystallinity and surface area increased in the sequence: water glass < colloidal silica < fumed silica, also the sample of synthesized by Fumed silica (Z-F) with higher crystallinity, shows better performance in the adsorption process.

## Keywords

Adsorption;  
Characterization;  
NaX zeolite;  
Silica sources;  
Synthesis.

## 1. Introduction

**Z**eolites are the most important family in crystalline microporous materials. The zeolite comprises infinitely extending three-dimensional network of aluminum and silicon tetrahedra linked to each other by the sharing of oxygen ions with uniformly sized pores of molecular dimensions [1]. Synthetic zeolites have been used in the petroleum industry in reactions such as cracking, alkylation, isomerization, shape reforming, hydro-

genation and dehydrogenation, adsorbents, catalysts, ion-exchangers and separation processes. Zeolites are of particular interest because of their remarkable properties, such as high hydrothermal stability, catalytic activity, excellent shape selectivity and adsorption capacities [2-4].

The increase of CO<sub>2</sub> emissions in the atmosphere leading to global warm in gas a serious environmental problem. The adsorbents reported for CO<sub>2</sub> adsorption such as zeolites, activated carbons [5-8], hydrotalcite [9] via physisorption in micropores [10]. Some of the more important zeolite types, which have been used in commercial applications, include the synthetic zeolite types A, X, Y [1]. Milton and Breck reported the discovery of zeolites A and

\* Corresponding Author.

Tel.: +98 21 77240516 / Fax: +98 21 77491204

E-mail: anbia@iust.ac.ir (M. Anbia)

X in 1959 at Union Carbide [11]. Zeolite X-type is an excellent adsorbent for gases such as carbon dioxide, nitrogen, argon and water vapors, due to large pore diameter (0.74 nm) with the same framework structural type as faujasite (FAU) [12].

Synthesis of NaX zeolites has been reported earlier using various precursor materials via hydrothermal reactions [13, 14]. It was found that chemical composition of the reactant mixture play most important role in the synthesis of zeolites [2, 4, 13]. The reactants have important effects on the crystallization of zeolites. The reactant sources (silica and alumina) affect the physico-chemical properties of final products [15, 16]. The choice of the silicon source may influence on the formation of a particular zeolite, morphology, crystal size, nucleation, the rate of crystallization and chemical properties of the zeolites [15-17]. Various silicon sources differ in reactivity and solubility [15]. Some of the important parameters attributed to the process of zeolite crystallization depend on the dissolution of the silica precursors [16].

Several reports have appeared on at the synthesis of this kind of zeolite such as ITQ-13, NaA, MFI, silicalite-1 and ZSM-5 using the different sources of silica and alumina [3, 4, 16, 18,19]. It is well known that the choice of silica source play an important role in the nucleation, crystallization of zeolites and also leads to changes in characteristic of the products [15, 20]. Much work have been done on the synthesis of NaX zeolites only with one silica source [13, 14], but a limited number of previous articles have investigated the synthesis of NaX zeolites by using different silica sources. Hamilton et al. [21] have reported that the silica source effects on the number of crystals in NaX zeolite and the only additive was varied in the batch composition. Jen Twuet al. [22] have reported that spectroscopic test of the zeolite growth stage is function of two sources of silicon. Krznaric et al. [17] have pointed that the equilibrium distributions of Na, Al, Si between the phases of gel formed by using different silica sources pertain on the batch chemical composition, but not the silica source utilized.

In this study, we have used several types of silica sources i.e. water glass, fumed silica and colloidal silica for the synthesis of NaX zeolite. The influence of different silica sources on the different aspects of zeolite crystallization and properties of the synthesized products has been investigated by analyses of structural (XRD, IR) and particulate properties (SEM) and the surface area as tested by nitrogen adsorption-desorption analysis. The CO<sub>2</sub> adsorption capacity of samples were also measured by the volumetric method.

## 2. Materials and Methods

### 2.1. Synthesis of Zeolite

All reactants were used as received without any further purification. Three types of silicon sources employed in NaX zeolite synthesis were aqueous colloidal silica (AM-30, 30wt% SiO<sub>2</sub>, Sigma-Aldrich), water glass (Merck) and fumed silica (Sigma-Aldrich). Sodium aluminate (Sigma-Aldrich) was used as alumina source. The sodium source used was sodium hydroxide pellets (Merck, 99%). NaX zeolite crystals of a uniform particle size have been prepared using three different silica sources by hydrothermal process. The solution of aluminosilicate gels used had the molar composition of 3.5Na<sub>2</sub>O:Al<sub>2</sub>O<sub>3</sub>:3 SiO<sub>2</sub>:150H<sub>2</sub>O [13, 23]. The hydrogel was made by dissolving specific amounts of sodium aluminate and sodium hydroxide pellets in deionized water, followed by adding one of the selected silica sources. The mixture was stirred for 1h, then was transferred to a Teflon-lined stainless steel autoclave for crystallization process at 90°C in different crystallization times under autogenous pressure. After completion of the crystallization, solid products were obtained by filtration and washed several times with deionized water and then dried at 100°C.

### 2.2. Samples characterization

The solid products prepared were characterized by a variety of routine techniques. X-ray diffraction (XRD) spectrums of the samples were taken by Philips 1830 diffractometer with Cu-K $\alpha$  radiation. The XRD data were aggregated in the 2 $\theta$  range between 5° and 40° (step time 1 s, step size 0.02°). The morphology characteristic of NaX zeolite samples were obtained by Scanning Electron Microscopy (SEM, TE scan-LVEGA II electron microscopy). Transmission IR spectra of the adsorbents were recorded on a DIGILAB FTS 7000 spectrometer equipped with an attenuated total reflection (ATR) cell, in the range of 400-4000 cm<sup>-1</sup>. The nitrogen adsorption-desorption experiments were measured on a Micromeritics model ASAP 2020 sorption analyzer at liquid nitrogen temperature (-196°C). Before measurement, the samples were degassed at 200°C for 2 h.

### 2.3. Experimental set-up

The CO<sub>2</sub> adsorption capacities of the products were measured by using a standard system based on volumetric method and the setup is shown in Figure 1. First, 1 g of a sample was loaded into the adsorption cell (13). Before measurement, the samples were degassed by using the vacuum

pump at 250°C for 1.5 h. The CO<sub>2</sub> adsorption measurements were carried out using high purity carbon dioxide (99.999%) and helium as the purge gas. The pressure of adsorption cell decreased some dead volume and some CO<sub>2</sub> adsorption. The exact pressure decrease because of CO<sub>2</sub> adsorption and then gas adsorption can be calculated. Details of the procedures and the equipments applied are explained in literature [24, 25].

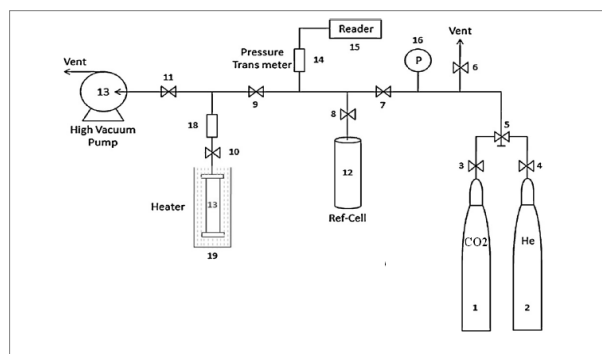

Figure 1. Set up for adsorption capacity test.

### 3. Results and Discussions

In this study, influence of several types of silica sources i.e. water glass, fumed silica and colloidal silica on the synthesis of NaX zeolite were investigated. The final products were characterized using X-ray, FT-IR, SEM, nitrogen adsorption-desorption analysis, also the adsorption of carbon dioxide for samples were studied.

#### 3.1. XRD analysis

X-ray powder diffraction is the most common method for determining the zeolite structure [11]. Figure 2 shows the XRD patterns of synthesized zeolites using different sources of silica such as colloidal silica, fumed silica and water glass. It is clear from Figure 2 that in all the synthesized samples NaX zeolite phase exists, as showed by sharp XRD peaks. On the other hand the characteristic XRD peaks of NaX zeolite at 2θ: 6.12°, 10°, 15.5° are exactly compatible with the reference sample [26]. It indicates that NaX zeolite can be synthesized by three silica sources as reported in literature [13, 14]. However, the intensity of peaks were different in XRDs. As shown in the figure, the peaks of Z-C and Z-F are more intense than Z-W, indicating that samples of Z-C and Z-F have higher crystallization. This is ascribed to when a monomeric silica source is utilized, crystal growth and nucleation take place

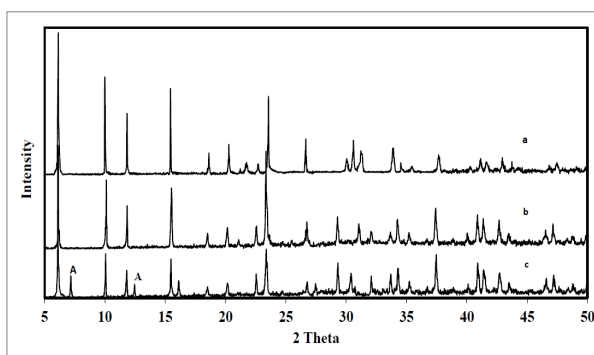

Figure 2. Effect of silica sources on crystallinity of synthesized zeolites (a) Z-F, (b) Z-C, (c) Z-W.

faster than when a highly condensed source of silica is utilized [16]. The effect of silica sources on percent crystallinity of synthesized NaX zeolites are presented in Table 1.

The surface area of silica sources was decreased as following: Fumed silica > silica colloid > water glass. It can be seen that the fumed silica has the highest surface area than the other sources. The silicon source with high surface area is more easily solved in basic solution than with low surface area. The silicon source with high surface area and high solubility leads to a faster nucleation in basic medium and is desirable for the formation of small crystals but the silicon source with low surface area and low solubility is desirable for the formation of large crystals [2, 15]. These results show that there was something different in the three source silicate, since other factors were constant between the three batches.

Table 2 shows the measured pH of zeolite solution using different silica source (after and before crystallization), are similar which is based on the fact that the solutions of silica source had the same batch compositions [21].

Table 1. Effect of silica sources in crystallinity of NaX zeolite.

Product of synthesized	Crystallinity of NaX, %	Phase formed
Z-F <sup>a</sup>	98	NaX
Z-C <sup>b</sup>	85	NaX
Z-W <sup>c</sup>	40	NaX+NaA

<sup>a</sup> Zeolite of synthesized by Fumed silica <sup>b</sup> Zeolite of synthesized by Colloidal silica <sup>c</sup> Zeolite of synthesized by Water glass

**Table 2.** Measurement of zeolite solution pH (before crystallization, after crystallization).

Silica source	before	after
Fumed silica	13.47	13.73
Colloidal silica	13.50	13.68
Water glass	13.53	13.70

### 3.2. FT-IR analysis

The FT-IR spectra of synthesized samples by using silica sources is shown in Figure 3. According to previous studies, IR results confirm that bands close to ( $560\text{ cm}^{-1}$  "characteristic of the existence of double six rings (D6R)"), ( $1060\text{--}971\text{ cm}^{-1}$  "characteristic of the asymmetric stretching due to the internal vibrations of Si-O-T linkage"), ( $820\text{--}750\text{ cm}^{-1}$  "characteristic of the symmetric stretching of the external linkage"), ( $458\text{ cm}^{-1}$  "characteristic of T-O bending vibration") are observed for synthesized samples by using silica sources such as colloidal silica, silica fumed and water glass [1, 27, 28]. The spectra of synthesized samples are in good agreement with the mentioned values above, and also when the crystallinity of synthesized samples grows, the bands become stronger [28]. In other words, the progress increase in intensity of bands indicates the increase in the crystallinity of the samples. The FT-IR results are in agreement with obtained XRD results.

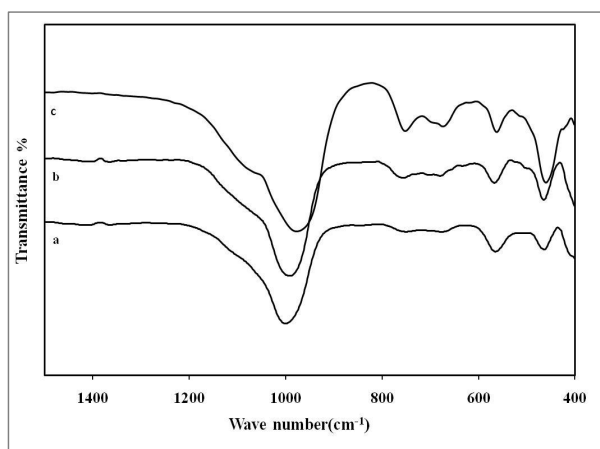
**Figure 3.** IR spectra of samples obtained by using different silica sources (a) Z-W, (b) Z-C, (c) Z-F.

### 3.3. Scanning electron microscopy (SEM)

Scanning electron microscopy (SEM) is the method of choice for determining the size and morphol-

ogy of zeolite crystallites [11]. The extra information about the influences of silica sources on the properties of NaX zeolites, SEM images were taken from the samples Z-C, Z-F and Z-W and are shown in Figure 4. SEM images indicate that synthesized samples consist of irregular and polygon particles whereas the crystal sizes of the final product were different. The SEM microphotograph reveals (Figure 4a and b) that fumed silica and colloidal silica yielded prominently NaX zeolite. Also, the morphology of samples Z-C and Z-F seems octahedral crystalline shape which is similar to reported in the literatures [12, 13]. However the sample prepared by water glass crystallized, cubic particles due to the NaA zeolite can be seen in addition to the octahedral particles. These results are compatible with the XRD and IR.

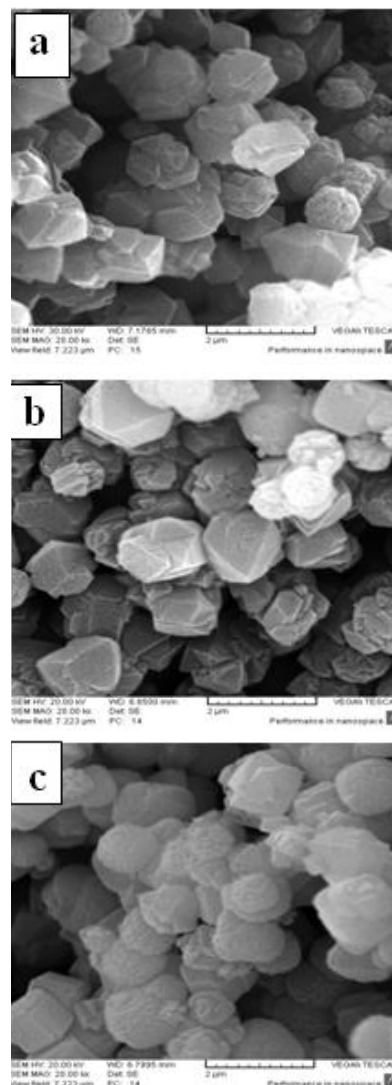
**Figure 4.** SEM images of synthesized samples (a) Z-F, (b) Z-C, (c) Z-W.

### 3.4. N<sub>2</sub> Adsorption-desorption isotherms analysis and isotherms of CO<sub>2</sub> adsorption

The effect of silica sources on the surface area and micropore volume of the synthesized zeolites is shown in Table 3. It can be seen that the surface area of samples due to decreasing crystallinity was decreased in the sequence: Z-F>Z-C>Z-W and also the sample of Z-F has the largest volume of micropores, this indicates that with decrease in micropore volume crystallinity is lower as estimated by XRD studies. The nitrogen adsorption-desorption isotherms of samples prepared by using fumed silica and colloidal silica are shown in Figure 5. It can be seen that the sample (a) has higher N<sub>2</sub> adsorption capacity at low pressure and the sample (b) has low adsorption capacity which is ascribed to higher crystallinity of the sample (a) [12, 13]. The samples of Z-F and Z-C demonstrate type I isotherms, that are characteristic of a microporous material [8].

The CO<sub>2</sub> adsorption isotherms of the samples are shown in Figure 6 at room temperature (25°C) and at different pressures in the range of 0 to 20 bar. It can be seen that the amounts adsorbed of CO<sub>2</sub> on the sample Z-F was higher than Z-C which may be ascribed to its higher surface area or micropore volume compared to the Z-C [8, 10] and may be explained by the fact that the sample with higher crystallinity, has better performance in the adsorption process. The high CO<sub>2</sub> uptake by NaX zeolite was ascribed to its microporous structure with charge cations in the cavities [8]. The amount of CO<sub>2</sub> adsorbed on Z-F at 25°C was close to the value reported in literature [29].

**Table 3.** Surface area and micropore volume for different samples.

Sample	SBET (m <sup>2</sup> /gr)	V <sub>micro</sub> (cm <sup>3</sup> /gr)
Z-F	650	0.34
Z-C	620	0.25
Z-W	500	0.19

Note: S<sub>BET</sub> = surface area; V<sub>micro</sub> = micropore volume

## 4. Conclusions

NaX zeolite can be synthesized using different silica sources (i.e. colloidal silica, fumed silica and water glass). The effect of different silica sources in

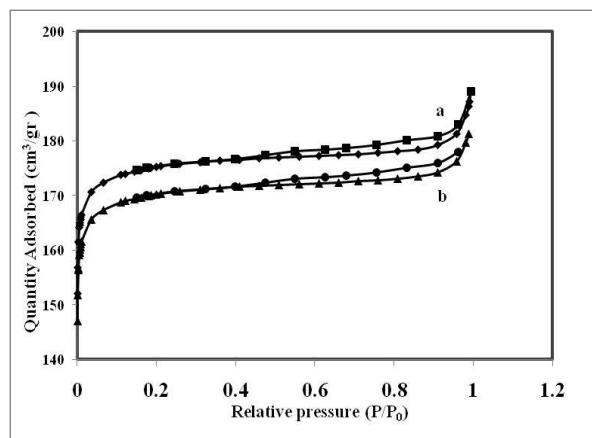

**Figure 5.** N<sub>2</sub> adsorption-desorption isotherms for samples (a) Z-F, (b) Z-C.

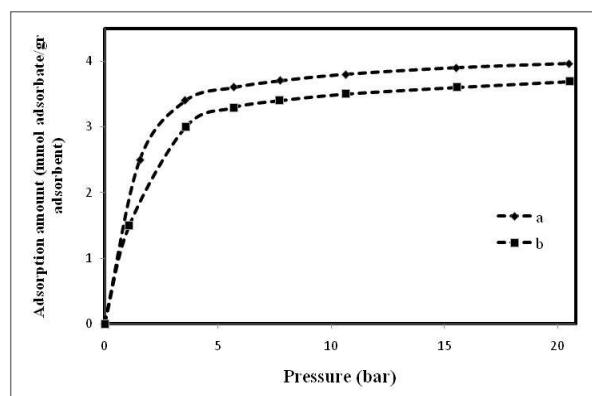

**Figure 6.** CO<sub>2</sub> adsorption isotherms of two adsorbents at temperature 25°C (a) Z-F, (b) Z-C.

the synthesis gel on the crystallinity end products were studied by XRD, FTIR, SEM, nitrogen adsorption-desorption isotherms. These results indicate that the use of silica sources with different surface areas was found to play a significant role on the crystallization rate of zeolite and leads to transformation in the properties of the end product. All of applied silica sources could prepare NaX, but the percent crystallinity of the samples Z-F, Z-C is more than Z-W and the crystallization rate of Z-W is lower. SEM data show that the samples which were prepared by fumed silica, colloid silica crystallized in octahedral shape crystals, however the sample prepared by water glass crystallized, cubic particles due to the NaA zeolite can be seen in addition to the octahedral particles. The equilibrium adsorption tests were performed by the volumetric method at temperature 25°C. The results indicated that the amounts adsorbed of CO<sub>2</sub> on the sample Z-F were higher than Z-C.

## References

1. Kulprathipanja, S., (2010). *Zeolite In Industrial Separation and Catalysis*, Wiley, USA.
2. Xu, R., Pang, W., Yu, J., Huo, Q., Chen, J., (2007). *Chemistry of Zeolites and Related porous materials: Synthesis and Structure*, John Wiley, Asia.
3. Kalita, B., Talukdar, A.K., (2009). "An efficient synthesis of nanocrystalline MFI zeolite using different silica sources: A green approach." *Materials Research Bulletin*, Vol. 44, No. 2, pp. 254-258.
4. Mintova, S., Valtchev, V., (2002). "Effect of the silica source on the formation of nanosized silicalite-1: an in situ dynamic light scattering study." *Microporous and Mesoporous Materials*, Vol. 55, No. 2, pp. 171-179.
5. Siriwardane, R.V., Shen, M.S., Fisher, E.P., Poston, J.A., (2001). "Adsorption of CO<sub>2</sub> on molecular sieves and activated carbon", *Energy & Fuels*, Vol. 15, No. 2, pp. 279-284.
6. Harlick, P., Tezel, F.H., (2004). "An experimental adsorbent screening study for CO<sub>2</sub> removal from N<sub>2</sub>." *Microporous and Mesoporous Materials*, Vol. 76, No. 1-3, pp. 71-79.
7. Chue, K.T., Kim, J.N., Yoo, Y.J., Cho, S.H., Yang, R.T., (1995). "Comparison of activated carbon and zeolite 13X for CO<sub>2</sub> recovery from flue gas by pressure swing adsorption." *Industrial & Engineering Chemistry Research*, Vol. 34, No. 2, pp. 591-598.
8. Chen, C., Park, D.W., Ahn, W.S., (2013). "CO<sub>2</sub> capture using zeolite 13X prepared from bentonite." *Applications of Surface Science*, Vol. 292, No. 1, pp. 63-67.
9. Yong, Z., Mata, V., Rodrigues, A.E., (2001). "Adsorption of carbon dioxide onto hydrotalcite-like compounds (HTLcs) at high temperatures." *Industrial & Engineering Chemistry Research*, Vol. 40, No. 6, pp. 204-209.
10. Anbia, M., Hoseini, V., (2012). "Development of MWCNT@MIL-101 hybrid composite with enhanced adsorption capacity for carbon dioxide." *Chemical Engineering Journal*, Vol. 191, No. 1, pp. 326-330.
11. Payra, P., Dutta, P., (2003). *Handbook of Zeolite Science and Technology*, Marcel Dekker, Inc, USA.
12. Chaves, T.F., Pastore, H.O., Cardoso, D., (2012). "A simple synthesis procedure to prepare nanosized faujasite crystals." *Microporous and Mesoporous Materials*, Vol. 161, No. 1, pp. 67-75.
13. Zhang, X., Tang, D., Zhang, M., Yang, R., (2013). "Synthesis of NaX zeolite: Influence of crystallization time, temperature and batch molar ratio SiO<sub>2</sub>/Al<sub>2</sub>O<sub>3</sub> on the particulate properties of zeolite crystals." *Powder Technology*, Vol. 235, No. 1, pp. 322-328.
14. Zhang, X., Tong, D., Zhao, J., Li, X., (2013). "Synthesis of NaX zeolite at room temperature and its characterization." *Materials Letters*, Vol. 104, No. 1, pp. 80-83.
15. Yu, J. (2007). *Studies in Surface Science and Catalysis*, Elsevier, Amsterdam.
16. Mohamed, R.M., Aly, H.M., El-Shahat, M.F., Ibrahim, I.A., (2005). "Effect of the silica sources on the crystallinity of nanosized ZSM-5 zeolite." *Microporous and Mesoporous Materials*, Vol. 79, No. 1-3, pp. 7-21.
17. Krznaric, I., Antonic, T., Bronic, J., Subotic, B., Thompson, R., (2003). "Influence of silica sources on the chemical composition of aluminosilicate hydrogels and the results of their hydrothermal treatment." *Croatica Chemica Acta*, Vol. 76, No. 1, pp. 7-17.
18. Chen, X., Jing-Qi, G., Shu-Jie, W., Qiu-Bin, K., (2009). "Effect of silica source on the hydrothermal synthesis of ITQ-13 zeolite." *Acta Physico-Chimica Sinica*, Vol. 25, No. 11, pp. 2275-2278.
19. Zhang, X., Tang, D., Jiang, G., (2013). "Synthesis of zeolite NaA at room temperature: The effect of synthesis parameters on crystal size and its size distribution." *Advanced Powder Technology*, Vol. 24, No. 3, pp. 689-696.
20. Breck, D.W. (1974). *Zeolite Molecular Sieves, Structure, Chemistry and Use*, John Wiley, New York.
21. Hamilton, K.E., Coker, E.N., Sacco, A., Jr, Dixon, A.G., Thompson, R.W., (1993). "The effects of

- the silica source on the crystallization of zeolite NaX.", *Zeolites*, Vol. 13, No. 8, pp. 645-653.
22. Twu, J., Dutta, P.K., (1991). "Raman spectroscopic studies of the synthesis of faujasitic zeolites: Comparison of two silica sources.", *Zeolites*, Vol. 11, No. 1, pp. 672-679.
  23. Deng, Z.S., Balkusjr, K.J., (2002). "Pulsed laser deposition of zeolite NaX thin films on silica fibrs.", *Microporous and Mesoporous Materials*, Vol. 56, No. 1, pp. 47-53.
  24. Anbia, M., Hoseini, V., Mandegarzarad, S., (2012). "Synthesis and characterization of nanocomposite MCM-48-PEHA-DEA and its application as CO<sub>2</sub> adsorbent.", *Journal of Chemical Engineering*, Vol. 29, No. 12, pp. 1776-1781.
  25. Anbia, M., Mandegarzarad, S., (2012). "Enhanced hydrogen sorption on modified MIL-101 with Pt/CMK-3 by hydrogen spillover effect.", *Journal of Alloys and Compounds*, Vol. 532, No. 1, pp. 61-67.
  26. Treacy, M.M.J., Higgins, J.B., (2001). *Collection of Simulated XRD Powder Patterns for Zeolites*. Elsevier, Amsterdam.
  27. Novembre, D., Di Sabatino, B., Gimeno, D., Garcia-Valles, M., Martinez-Manent, S., (2004). "Synthesis of Na-X zeolites from tripolaceous deposits (Crotona, Italy) and volcanic zeolitized rocks (Vico volcano, Italy).", *Microporous and Mesoporous Materials*, Vol. 75, No. 1-2, pp. 1-11.
  28. Flanigen, E.M., Khatami, H.A., Szymanski, H.A., (1971). *Infrared structural study of zeolite frame-works. Molecular Sieve Zeolites.*, Advances in Chemistry Series, American Chemical Society, Washington.
  29. Zhang, Z., Zhang, W., Chen, X., Xia, Q., Li, Z., (2010). "Adsorption of CO<sub>2</sub> on zeolite 13X and activated carbon with higher surface area." *Separation Science and Technology*, Vol. 45, No. 5, pp. 710-719.